

Instruments Used:
Vector Vane
Vector Instruments Anemometer
Windsensor P2546A & P2546C Anemometer

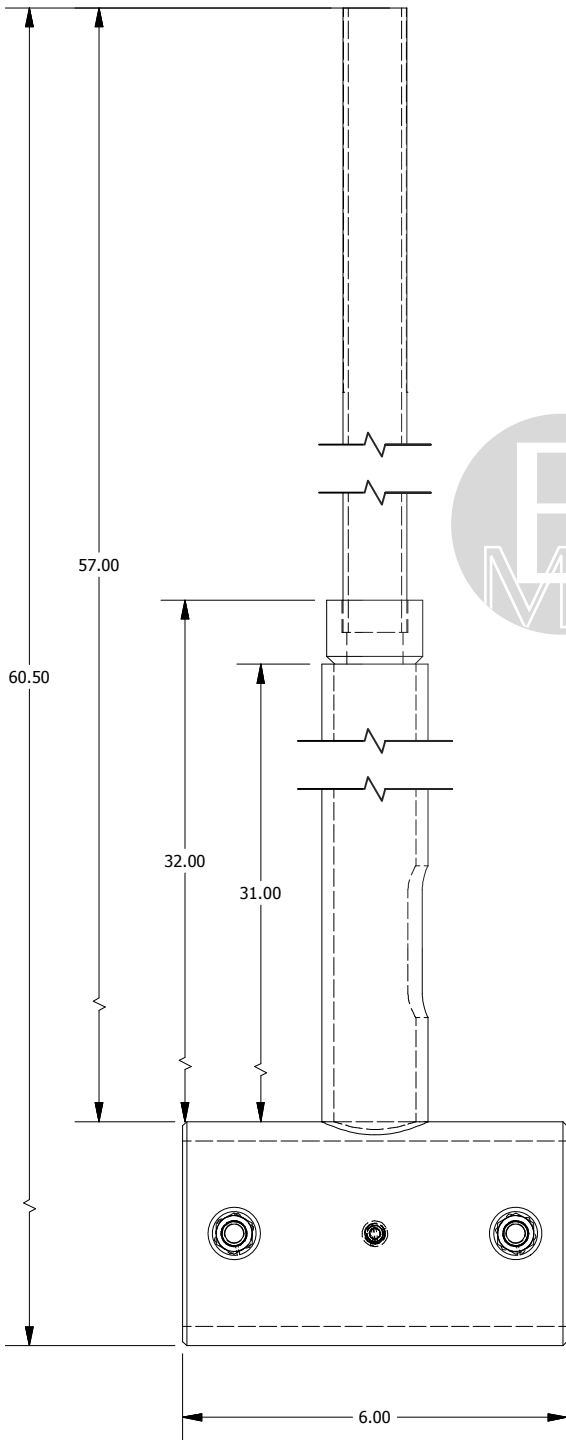

EDCO
METAL
FABRICATORS

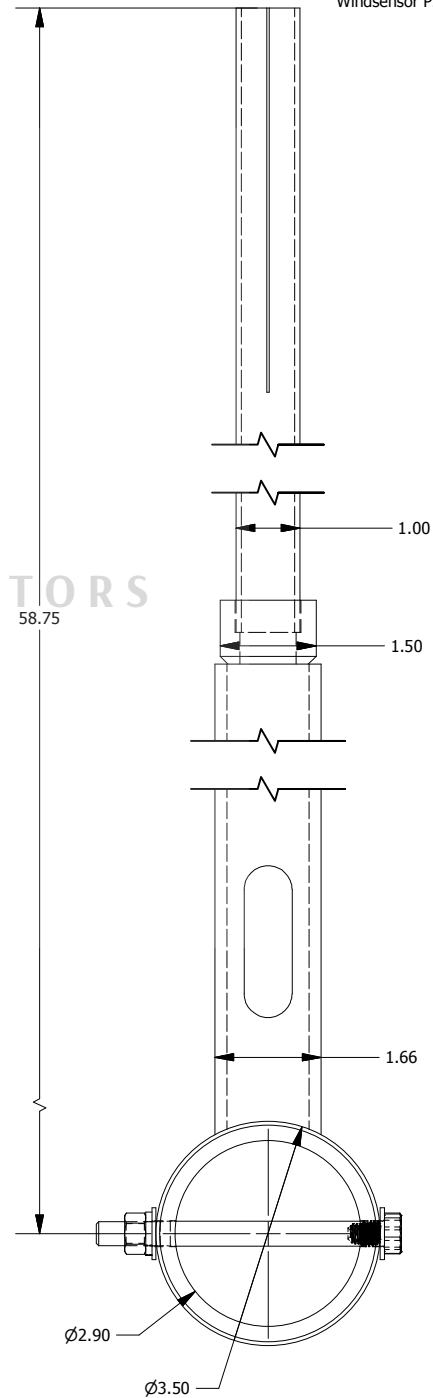

PROPRIETARY
The information contained in this drawing is the
sole property of EDCO INC Any reproduction or
use in part or as a whole without the written
permission of EDCO INC is prohibited.