

Instruments Used:
RM Young Wind Monitor - 25D
Thies First Class Advanced Anemometer - 25D
Thies First Class Advanced Wind Vane - 25D
RM Young 81000 3D US - 25D

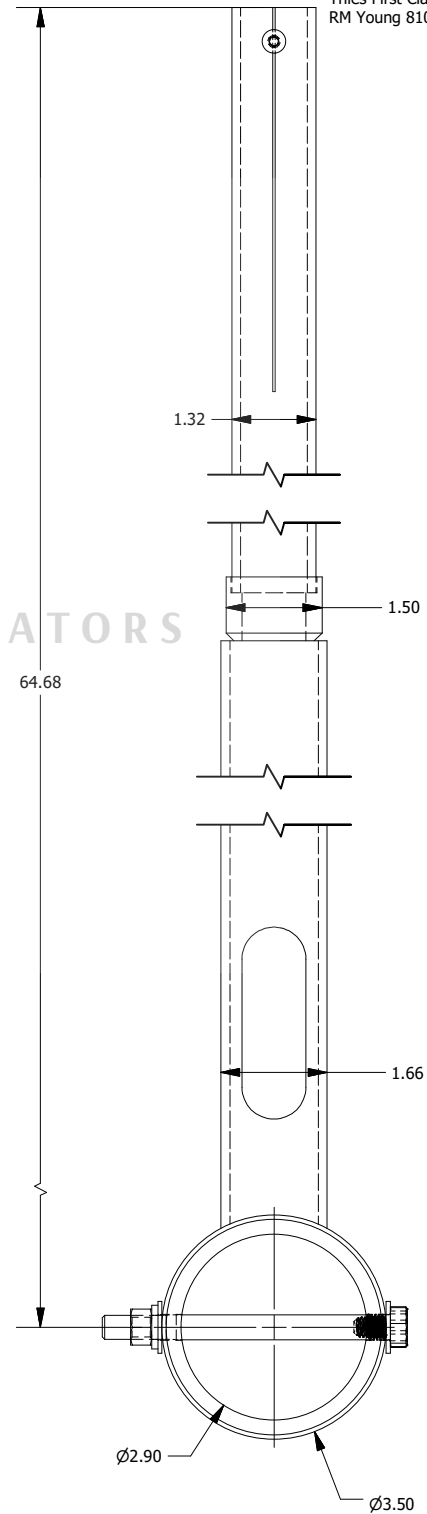
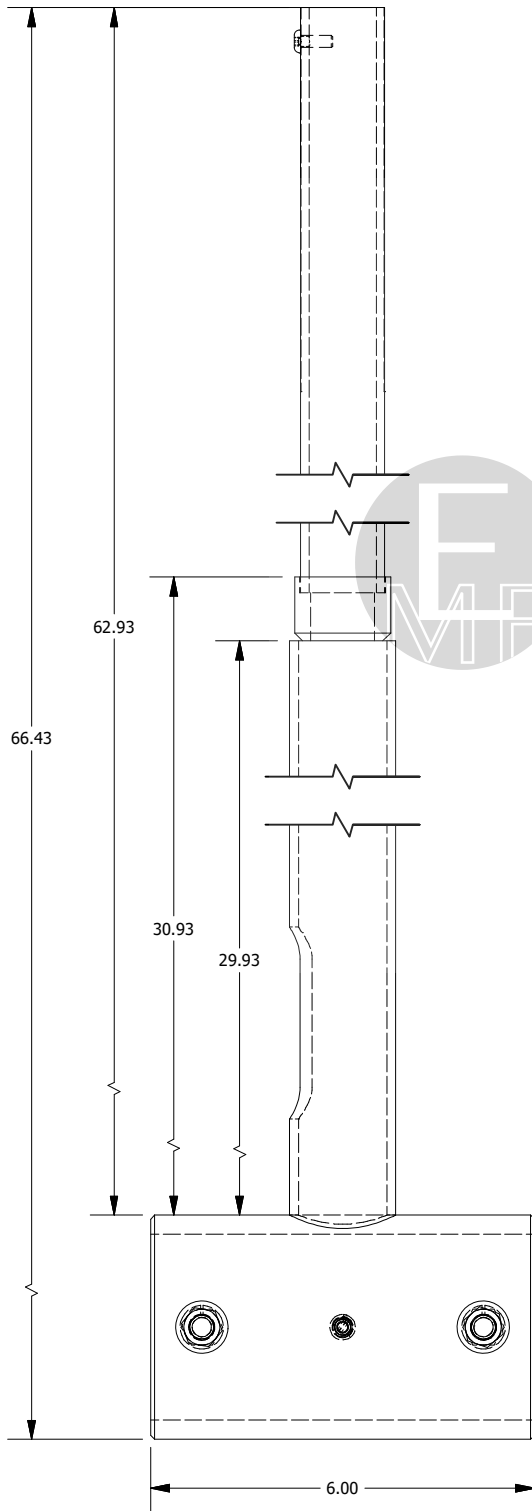

Ø2.90

Ø3.50

PROPRIETARY

The information contained in this drawing is the sole property of EDCO INC. Any reproduction or use in part or as a whole without the written permission of EDCO INC is prohibited.